

JMS AG
 Jet Maintenance & Service
 Rainer-Haungs-Strasse 42
 77933 Lahr/Germany
 Phone +49 (7821) 9 94 69 – 0
 Fax +49 (7821) 9 94 69 – 100



Internet: <http://www.jms.aero/>
 eMail: <mailto:sales@jms.aero>
 HRB 705130 Amtsgericht Freiburg i.Br.
 VAT Reg No/USt.-IdNr.: DE270217003
 Doc. No. TDS J-CART-6BO-
 BOOSTER_R01.docx

Datasheet:

p/n: J-CART-6BO-BOOSTER

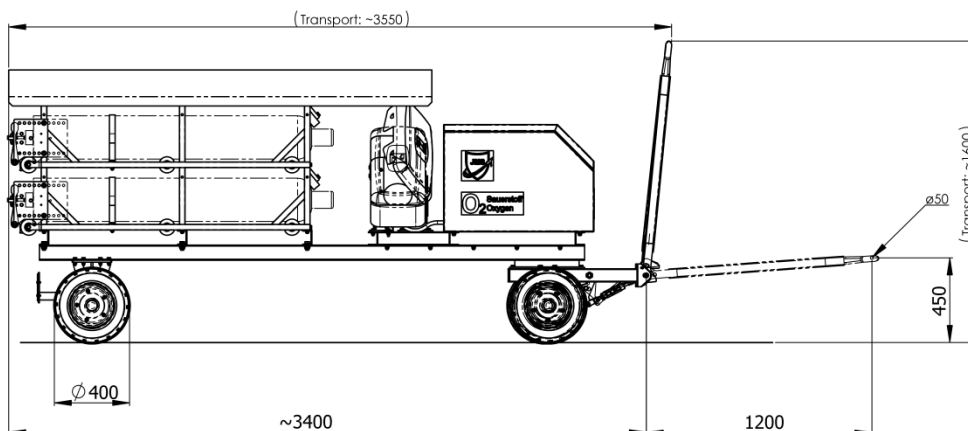

Picture may show options.

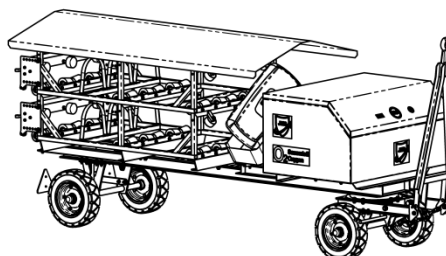

Description:

Aircraft/Cockpit Oxygen/O₂ servicing cart for servicing 1850 psi standard Aviator's Breathing Oxygen bottles

Standard features/including:

- Trailer/steel frame with tow bar, Diam. 2"/50mm tow-eye, four air-inflated tires
- Horizontal storage rack for qty. 6 off DIN-standard bottles (up to 4 off O₂ bottles combined with up to 4 off N₂ bottles acting as pressure source for booster), V=50 l, p=200 bar/2900 psi
- Frame hot-dip galvanized
- Grounding cable
- Pneumatic oxygen booster with operator panel (incl. inlet/outlet manometers + connection hoses etc.)
- Aircraft O₂ panel servicing hose, 10 m (connectors to be specified individually)
- 6kg ABC Powder Fire-Extinguisher incl. box

Options (at extra charges):

- Puncture-proof tires
 ➔ Option R4
- Oxygen bottle, p=200 bar, V=50 l incl. valve
 ➔ J-CART-BOTTLE-O2
- Protective canopy
 ➔ J-CANOPY
- Supply pressure gauge with calibration certificate i.a.w. DKD

Documentation:

- Technical manual incl. illustrated spare parts list
- COC Certificate of Conformity

Net weight (without options):

- 490 kg/1080 lbs

Shipping dimensions incl. packing:

Approx. Weight	Approx. shipping Dim. l x w x h	Approx. Volume
[kg]	[mm]	[m ³]
500	3550 x 1150 x 1600	6,5
[lbs]	[inch]	[ft ³]
1100	140 x 45 x 63	230,6

We reserve the right to update this datasheet at any time w/o prior notice!