

**JMS AG**  
 Jet Maintenance & Service  
 Rainer-Haungs-Strasse 42  
 77933 Lahr/Germany  
 Phone +49 (7821) 9 94 69 – 0  
 Fax +49 (7821) 9 94 69 – 100



Internet: <http://www.jms.aero/>  
 eMail: <mailto:sales@jms.aero>

HRB 705130 Amtsgericht Freiburg i.Br.  
 VAT Reg No/USSt.-IdNr.: DE270217003

Doc. No. TDS J-TOW134\_R02.docx

**Datasheet:**

**p/n: J-TOW134**

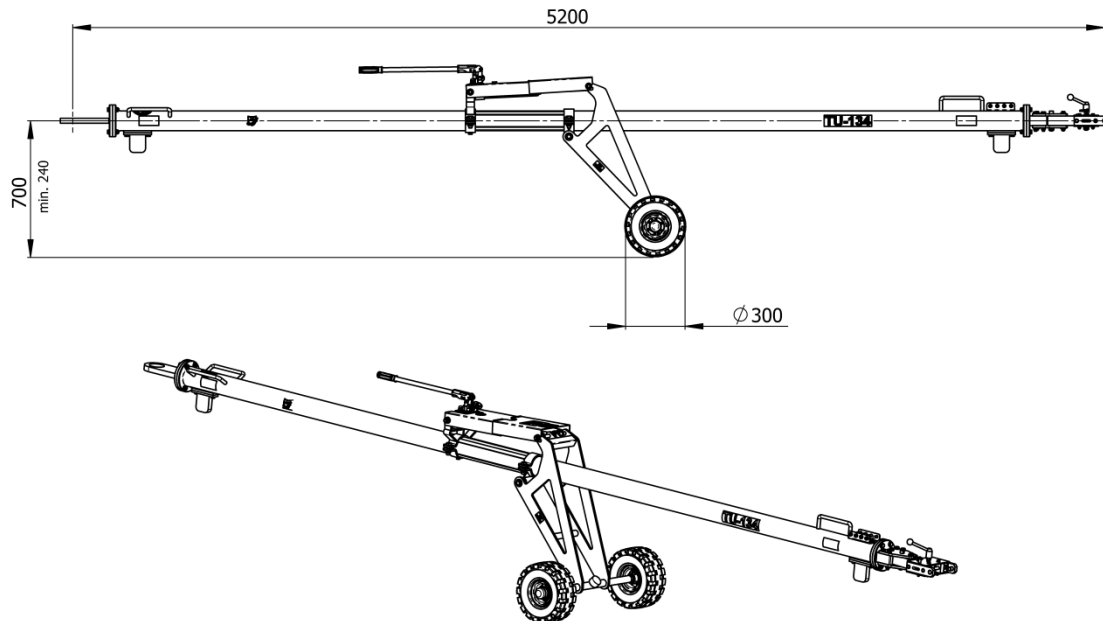

**Standard features:**

- Push/Pull and torque shear pin
- 4 spare shear pins included
- Retaining pin
- Air-inflated tires
- Hydraulically height adjustable undercarriage
- Steel tube
- Skydrol resistant paint
- Standard colors: yellow RAL 1007 (tube), black RAL 9004 (undercarriage)

**Options (at extra charges):**

- Puncture-proof tires
- Revolving tow eye
- Revolving tow eye with shock absorber
- Customized color for towbar tube i.a.w. RAL coding scheme

**Aircraft application:**

- TU-134

**Documentation:**

- Technical manual incl. illustrated spare parts list
- COC Certificate of Conformity
- CE Declaration of Conformity (if applicable)

**Net weight:**

- 135 kg / 297 lbs

**Shear pins:**

- 00.36910.0013 "E" for Push/Pull
- 00.40780.0012 "AD" for Torque
- 20-00830-0020-021 "AC-FB" Retaining pin

**Shipping information incl. packing:**

Approx. Weight	Approx. shipping Dims l x w x h	Approx. Volume
[kg]	[mm]	[m <sup>3</sup> ]
<b>200</b>	<b>5300 x 1000 x 720</b>	<b>3,8</b>
[lbs]	[inch]	[ft <sup>3</sup> ]
<b>440</b>	<b>208 x 39 x 28</b>	<b>134</b>

We reserve the right to update this datasheet at any time w/o prior notice!