

JMS AG
 Jet Maintenance & Service
 Rainer-Haungs-Strasse 42
 77933 Lahr/Germany
 Phone +49 (7821) 9 94 69 – 0
 Fax +49 (7821) 9 94 69 – 100



Internet: <http://www.jms.aero/>
 eMail: <mailto:sales@jms.aero>

HRB 705130 Amtsgericht Freiburg i.Br.
 VAT Reg No/USSt.-IdNr.: DE270217003

Doc. No. TDS J-TOWmi26_R01.doc

Datasheet:

p/n: J-TOWmi26

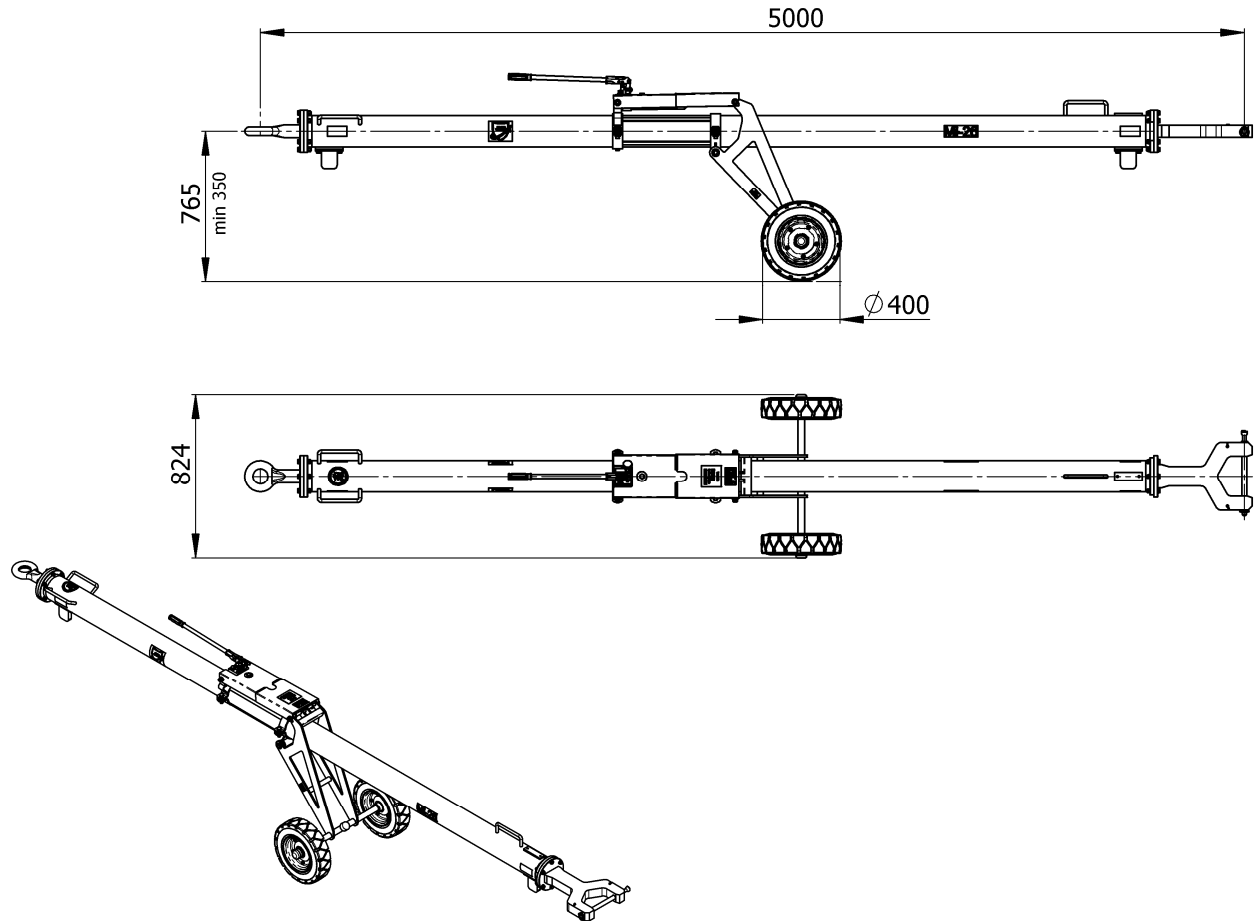

Standard features:

- Air-inflated tires
- Hydraulically height adjustable undercarriage
- Steel tube
- Skydrol resistant paint
- Standard color yellow RAL 1007

Options (at extra charges):

- Puncture-proof tires
- Revolving tow eye
- Revolving tow eye with shock absorber
- Revolving tow head ± 10°
- Customized color i.a.w. RAL coding

Helicopter application:

- Mi-26

Documentation:

- Technical manual
incl. illustrated spare parts list
- COC Certificate of Conformity
- CE Declaration of Conformity (if applicable)

Shipping information incl. packing:

Approx. Weight	Approx. shipping Dims l x w x h	Approx. Volume
[kg]	[mm]	[m ³]
300	5300 x 900 x 800	3,8
[lbs]	[inch]	[ft ³]
661	209 x 35 x 32	134

Net weight:

- 225 kg / 496 lbs

We reserve the right to update this datasheet at any time w/o prior notice!