

JMS AG
 Jet Maintenance & Service
 Rainer-Haungs-Strasse 42
 77933 Lahr/Germany
 Phone +49 (7821) 9 94 69 – 0
 Fax +49 (7821) 9 94 69 – 100



Internet: <http://www.jms.aero/>
 eMail: <mailto:sales@jms.aero>

HRB 705130 Amtsgericht Freiburg i.Br.
 VAT Reg No/USSt.-IdNr.: DE270217003

Doc. No. TDS J-TOWyk42-S_R00.docx

Datasheet:

p/n: J-TOWyk42-S

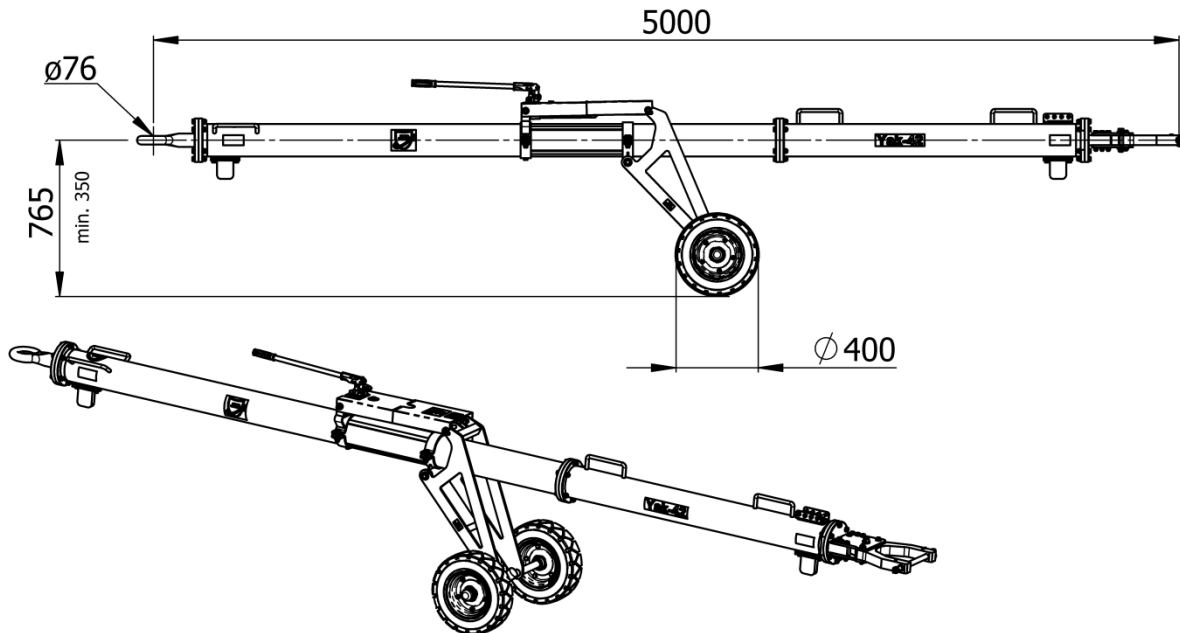

Standard features:

- Push/Pull and torque shear pin
- 4 spare shear pins included
- Air-inflated tires
- Hydraulically height adjustable undercarriage
- Split Steel tube
- Skydrol resistant paint
- Standard colors:
 yellow RAL 1007 (tube),
 black RAL 9004 (undercarriage)

Options (at extra charges):

- Puncture-proof tires
- Revolving tow eye
- Revolving tow eye with shock absorber
- Customized color for towbar tube i.a.w. RAL coding scheme

Documentation:

- Technical manual incl. illustrated spare parts list
- COC Certificate of Conformity
- CE Declaration of Conformity (if applicable)

Aircraft application:

- Yak-42

Shear pins:

- 00.37200.0012 “H” Push/Pull and Torque
- 00.37720.0018 “U-FB” Retaining pin

Net weight:

- 220 kg / 485 lbs

Shipping information incl. packing:

Approx. Weight	Approx. shipping Dims l x w x h	Approx. Volume
[kg]	[mm]	[m ³]
280	3250 x 1000 x 800	2,6
[lbs]	[inch]	[ft ³]
617	128 x 39 x 31.5	92

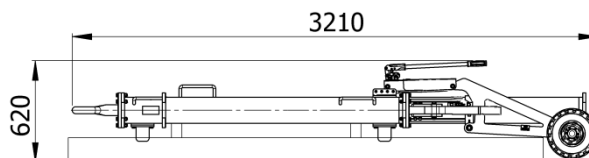

We reserve the right to update this datasheet at any time w/o prior notice!