

JMS AG
 Jet Maintenance & Service
 Rainer-Haungs-Strasse 42
 77933 Lahr/Germany
 Phone +49 (7821) 9 94 69 – 0
 Fax +49 (7821) 9 94 69 – 100



Internet: <http://www.jms.aero/>
 eMail: <mailto:sales@jms.aero>

HRB 705130 Amtsgericht Freiburg i.Br.
 VAT Reg No/USSt.-IdNr.: DE270217003

Doc. No. TDS_J-TOWsj100_R03.docx

Datasheet:

p/n: J-TOWsj100

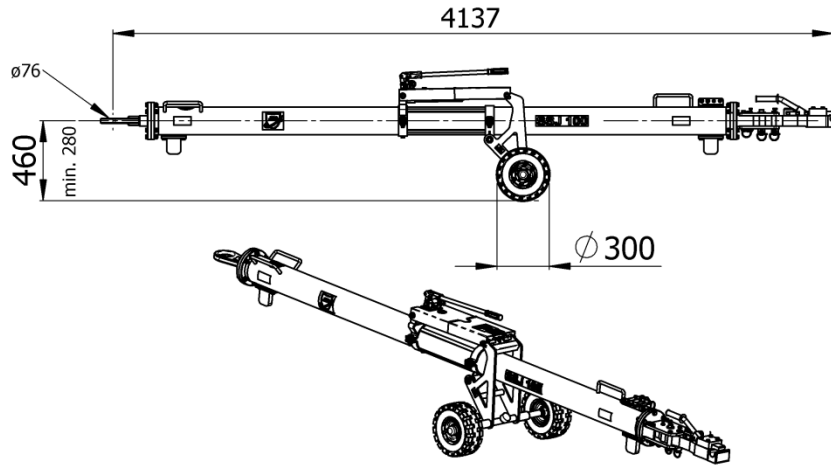

Standard features:

- Push/Pull and torque shear pins, replaceable without using tools
- FOD-Protection device:
No shear pin debris will be lost in case of shear pin fracture!
- 4 spare shear pins included
- Retaining pin
- Automatic locking mechanism
- Air-inflated tires
- Hydraulically height adjustable undercarriage
- Steel tube
- Skydrol resistant paint
- Standard colors: yellow RAL 1007 (tube), black RAL 9004 (undercarriage)

Options (at extra charges):

- Puncture-proof (full rubber) tires
→ Option R3
- Floating axle
→ Option BV
- Revolving tow head $\pm 10^\circ$
→ Option BD
- Revolving tow eye
→ Option BP
- Revolving tow eye with shock absorber
→ Option BA
- Customized color for towbar tube i.a.w. RAL coding scheme
→ Option B-RAL

Documentation:

- Technical manual incl. illustrated spare parts list
- COC Certificate of Conformity
- CE Declaration of Conformity (if applicable)

Net weight:

- 198 kg / 436 lbs

Aircraft application:

- SUKHOI SUPERJET 100

Shear pins:

- 20-01130-0020-022 "AP2" Push/Pull
- 20-00730-0020-022 "A1" Torque
- 20-01130-0020-021 "AP1-FB" Retaining pin

Shipping information incl. packing:

Approx. Weight	Approx. shipping Dims l x w x h	Approx. Volume
[kg] 263	[mm] 4250 x 1000 x 720	[m ³] 3,0
[lbs] 579	[inch] 167 x 39 x 28	[ft ³] 105.9

We reserve the right to update this datasheet at any time w/o prior notice!