

JMS AG
 Jet Maintenance & Service
 Rainer-Haungs-Strasse 42
 77933 Lahr/Germany
 Phone +49 (7821) 9 94 69 – 0
 Fax +49 (7821) 9 94 69 – 100



Internet: <http://www.jms.aero/>
 eMail: <mailto:sales@jms.aero>

HRB 705130 Amtsgericht Freiburg i.Br.
 VAT Reg No/USSt.-IdNr.: DE270217003

Doc. No. TDS_J-TOW148_R01.docx

Datasheet:

p/n: J-TOW148

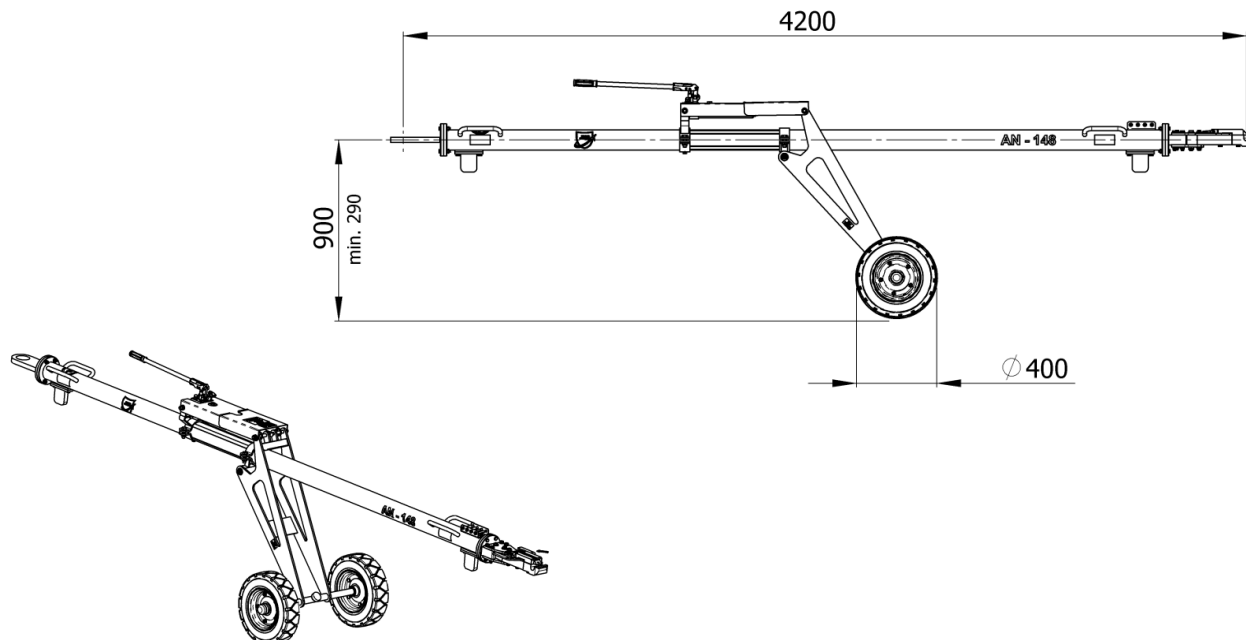

Standard features:

- Push/Pull and torque shear pin
- 4 spare shear pins included
- Retaining pin
- Air-inflated tires
- Hydraulically height adjustable undercarriage
- Steel tube
- Skydrol resistant paint
- Standard colors: yellow RAL 1007 (tube), black RAL 9004 (undercarriage)

Options (at extra charges):

- Puncture-proof (full rubber) tires
 → Option R4
- Revolving tow eye
 → Option CP
- Revolving tow eye with shock absorber
 → Option CA
- Customized color for towbar tube i.a.w. RAL coding scheme
 → Option C-RAL

Documentation:

- Technical manual incl. illustrated spare parts list
- COC Certificate of Conformity
- CE Declaration of Conformity (if applicable)

Net weight:

- 145 kg / 320 lbs

Aircraft application:

- Antonov AN-148 / -158

Shear pins:

- 00.41070.0012 "AK" for Push/Pull
- 00.41070.0013 "AL" for Torque
- 00.41070.0016 "AK-FB" Retaining pin

Shipping information incl. packing:

Approx. Weight	Approx. shipping Dims l x w x h	Approx. Volume
[kg] 210	[mm] 4320 x 1000 x 720	[m ³] 3,1
[lbs] 462	[inch] 170 x 39 x 28	[ft ³] 109.4