

**JMS AG**  
 Jet Maintenance & Service  
 Rainer-Haungs-Strasse 42  
 77933 Lahr/Germany  
 Phone +49 (7821) 9 94 69 – 0  
 Fax +49 (7821) 9 94 69 – 100



Internet: <http://www.jms.aero/>  
 eMail: <mailto:sales@jms.aero>

HRB 705130 Amtsgericht Freiburg i.Br.  
 VAT Reg No/USSt.-IdNr.: DE270217003

Doc. No. TDS J-TOW18\_R00.docx

**Datasheet:**

**p/n: J-TOW18**

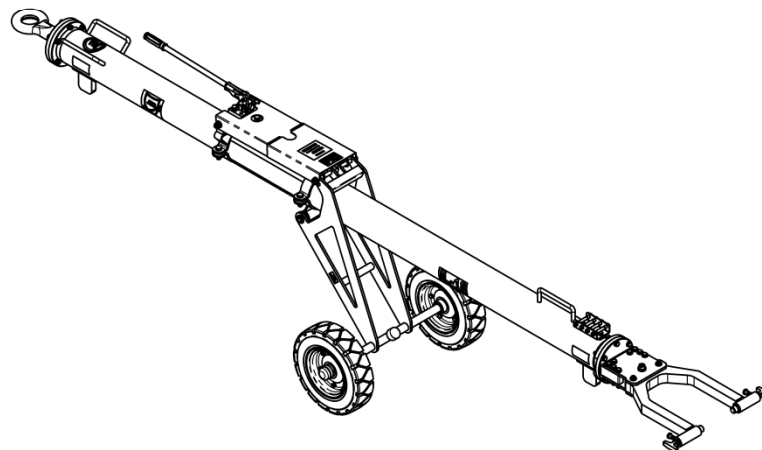
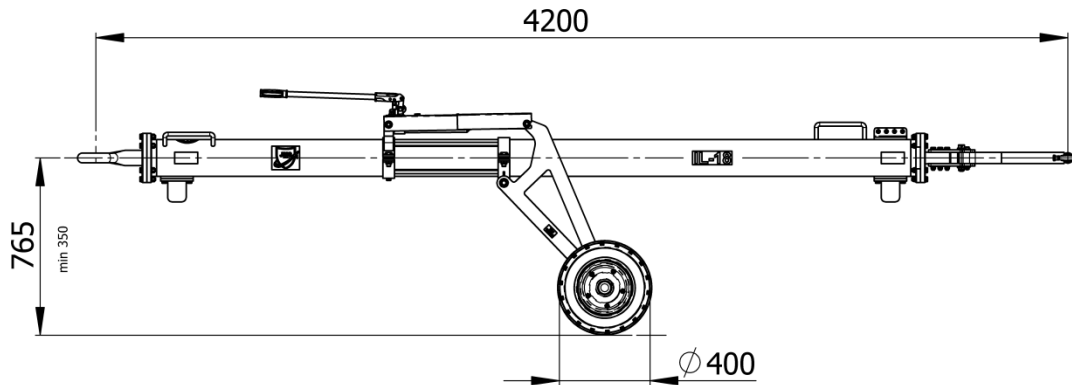

**Standard features:**

- Air-inflated tires
- Hydraulically height adjustable undercarriage
- Steel tube
- Skydrol resistant paint
- Standard colors: yellow RAL 1007 (tube), black RAL 9004 (undercarriage)

**Options (at extra charges):**

- Puncture-proof tires  
→ Option R4
- Revolving tow eye  
→ Option BP
- Revolving tow eye with shock absorber  
→ Option BA
- Revolving tow head ± 10°  
→ Option BD
- Customized color for towbar tube i.a.w. RAL coding scheme  
→ Option B-RAL

**Aircraft application:**

- IL-18
- IL-38

**Shipping information incl. packing:**

Approx. Weight	Approx. shipping Dims l x w x h	Approx. Volume
[kg] <b>265</b>	[mm] <b>4300 x 1000 x 800</b>	[m³] <b>3,4</b>
[lbs] <b>584</b>	[inch] <b>209 x 39 x 32</b>	[ft³] <b>120</b>

**Documentation:**

- Technical manual incl. illustrated spare parts list
- COC Certificate of Conformity
- CE Declaration of Conformity (if applicable)

**Net weight:**

- 200 kg / 440 lbs

We reserve the right to update this datasheet at any time w/o prior notice!