

JMS AG
 Jet Maintenance & Service
 Rainer-Haungs-Strasse 42
 77933 Lahr/Germany
 Phone +49 (7821) 9 94 69 – 0
 Fax +49 (7821) 9 94 69 – 100



Internet: <http://www.jms.aero/>
 eMail: <mailto:sales@jms.aero>

HRB 705130 Amtsgericht Freiburg i.Br.
 VAT Reg No/USSt.-IdNr.: DE270217003

Doc. No. TDS J-TOW320-S_R02.docx

Datasheet:

p/n: J-TOW320-S

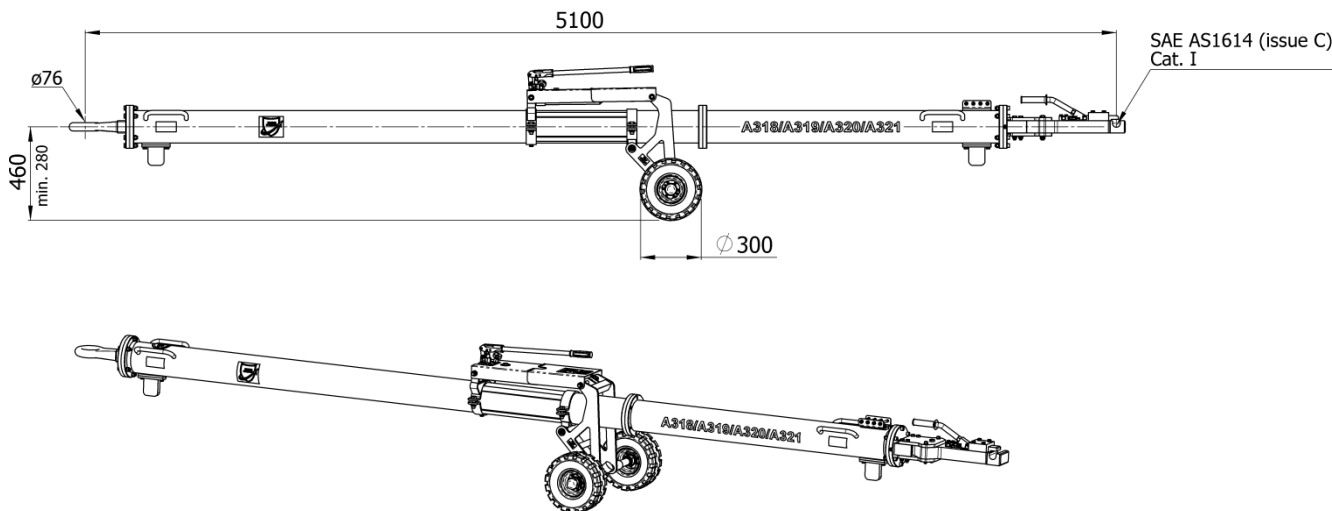

Standard features:

- Push/Pull and torque shear pin
- 4 spare shear pins included
- Retaining pin
- Air-inflated tires
- Hydraulically height adjustable undercarriage
- Revolving tow head $\pm 10^\circ$
 (requirement as per Airbus MFP for A318/A319/A320/A321 a/c)
- Split steel tube
- Skydrol resistant paint
- Standard colors: yellow RAL 1007 (tube), black RAL 9004 (undercarriage)

Options (at extra charges):

- Puncture-proof tires
- Floating axle
- Revolving tow eye
- Revolving tow eye with shock absorber
- Customized color for towbar tube i.a.w. RAL coding scheme

Documentation:

- Technical manual incl. illustrated spare parts list
- COC Certificate of Conformity
- CE Declaration of Conformity (if applicable)

Aircraft application:

- A318/A319/A320/A321

Shear pins:

- 20-00730-0020-022 "A1" Push/Pull and Torque
- 00.38910.0007 "A-FB" Retaining pin

Net weight:

- 235 kg / 518 lbs

Shipping information incl. packing:

Approx. Weight	Approx. shipping Dims l x w x h	Approx. Volume
[kg]	[mm]	[m ³]
305	3250 x 1000 x 700	2,27
[lbs]	[inch]	[ft ³]
672	128 x 39 x 27	80.1

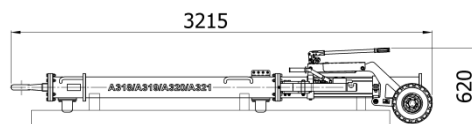

We reserve the right to update this datasheet at any time w/o prior notice!