

**JMS AG**  
 Jet Maintenance & Service  
 Rainer-Haungs-Strasse 42  
 77933 Lahr/Germany  
 Phone +49 (7821) 9 94 69 – 0  
 Fax +49 (7821) 9 94 69 – 100



Internet: <http://www.jms.aero/>  
 eMail: <mailto:sales@jms.aero>

HRB 705130 Amtsgericht Freiburg i.Br.  
 VAT Reg No/USSt.-IdNr.: DE270217003

Doc. No. TDS J-TOW787\_R03.docx

**Datasheet:**

**p/n: J-TOW787**

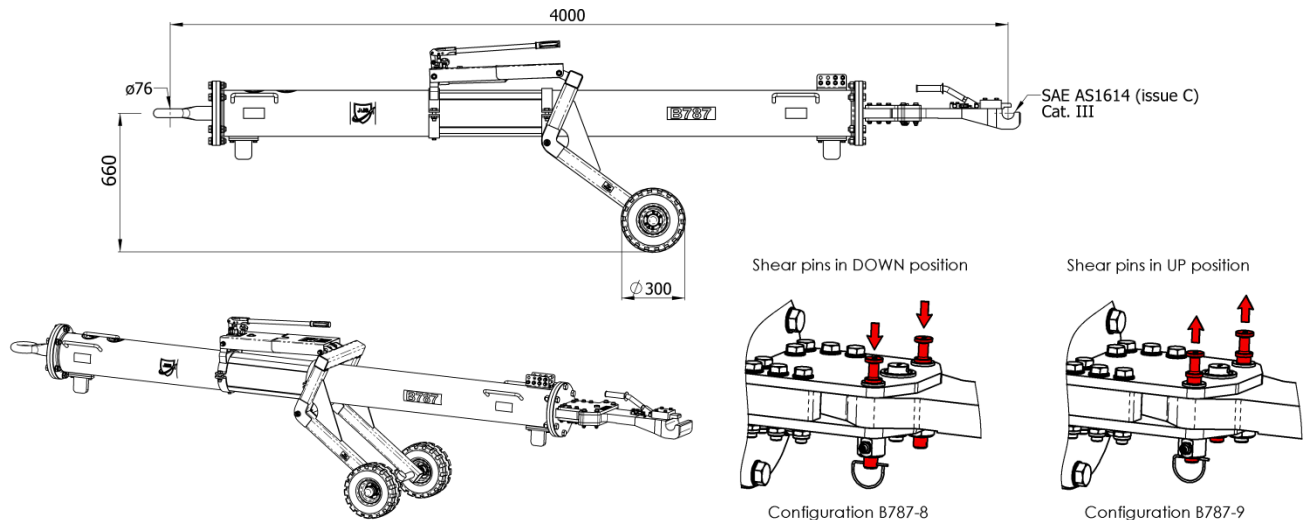

**Standard features:**

- Push/Pull and torque shear pins, replaceable without using tools.
- FOD-Protection device:  
No shear pin debris will be lost in case of shear pin fracture!
- 4 spare shear pins included
- Retaining pin
- Air-inflated tires
- Hydraulically height adjustable undercarriage
- Steel tube
- Skydrol resistant paint
- Standard colors: yellow RAL 1007 (tube), black RAL 9004 (undercarriage)

**Options (at extra charges):**

- Puncture-proof tires  
→ Option R3
- Floating axle  
→ Option AV
- Revolving tow head  $\pm 10^\circ$   
→ Option AD
- Revolving tow eye  
→ Option AP
- Revolving tow eye with shock absorber  
→ Option AA
- Customized color for towbar tube i.a.w. RAL coding scheme  
→ Option A-RAL

**Aircraft application:**

- B787

**Net weight:**

- 290 kg / 639 lbs

**Documentation:**

- Technical manual incl. illustrated spare parts list
- COC Certificate of Conformity
- CE Declaration of Conformity (if applicable)

**Shear pins:**

- 20-00230-0020-122 "AU" Push/Pull and Torque
- 00.40060.0008 "L-FB" Retaining pin

**Shipping information incl. packing:**

Approx. Weight	Approx. shipping Dims l x w x h	Approx. Volume
[kg]	[mm]	[m <sup>3</sup> ]
<b>355</b>	<b>4200 x 1000 x 760</b>	<b>3,2</b>
[lbs]	[inch]	[ft <sup>3</sup> ]
<b>782</b>	<b>165 x 39 x 30</b>	<b>113</b>

We reserve the right to update this datasheet at any time w/o prior notice!