

JMS AG
 Jet Maintenance & Service
 Rainer-Haungs-Strasse 42
 77933 Lahr/Germany
 Phone +49 (7821) 9 94 69 – 0
 Fax +49 (7821) 9 94 69 – 100



Internet: <http://www.jms.aero/>
 eMail: <mailto:sales@jms.aero>

HRB 705130 Amtsgericht Freiburg i.Br.
 VAT Reg No/USSt.-IdNr.: DE270217003

Doc. No. TDS J-TOWc100_R02.docx

Datasheet:

p/n: J-TOWc100

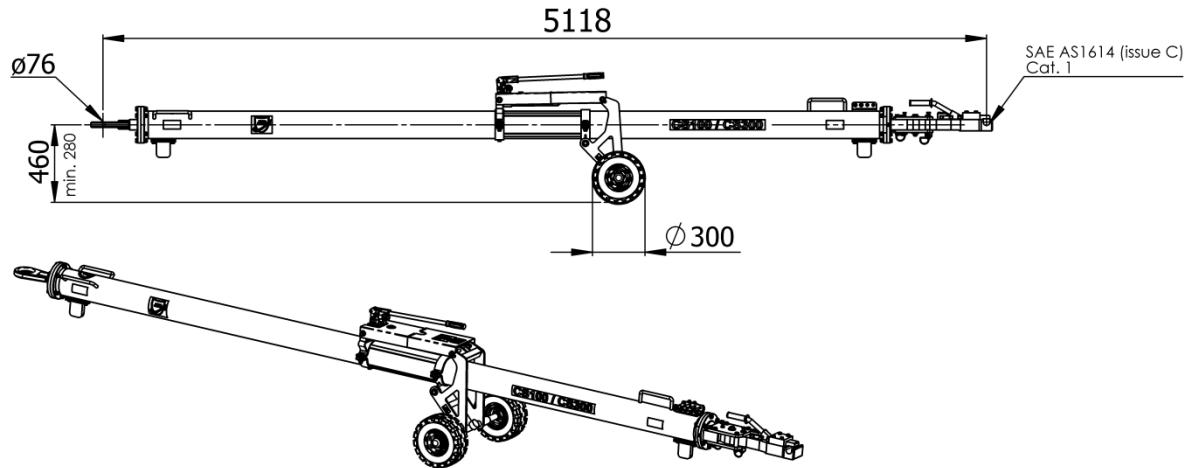

Standard features:

- Push/Pull and torque shear pin
- 4 spare shear pins included
- Retaining pin
- Air-inflated tires
- Hydraulically height adjustable undercarriage
- Revolving tow head $\pm 10^\circ$ (required due to NLG at an angle)
- Steel tube
- Skydrol resistant paint
- Standard colors: yellow RAL 1007
black RAL 9004 (undercarriage)

Options (at extra charges):

- Puncture-proof tires
→ Option R3
- Floating axle
→ Option BV
- Revolving tow eye
→ Option BP
- Revolving tow eye with shock absorber
→ Option BA
- Customized color for towbar tube i.a.w. RAL coding scheme
→ Option B-RAL

Aircraft application:

- Bombardier - CS100 / CS300

Documentation:

- Technical manual incl. illustrated spare parts list
- COC Certificate of Conformity
- CE Declaration of Conformity (if applicable)

Net weight:

- 230 kg / 507 lbs

Shear pins:

- 20-01080-0020-022 "BC" Push/Pull
- 20-01080-0020-025 "BD" Torque
- 20-01080-0020-021 "BC-FB" Retaining pin

Shipping information incl. packing:

Approx. Weight	Approx. shipping Dims l x w x h	Approx. Volume
[kg] 295	[mm] 5320 x 1000 x 720	[m ³] 3,8
[lbs] 650	[inch] 209 x 39 x 28	[ft ³] 134.2

We reserve the right to update this datasheet at any time w/o prior notice!