

JMS AG
 Jet Maintenance & Service
 Rainer-Haungs-Strasse 42
 77933 Lahr/Germany
 Phone +49 (7821) 9 94 69 – 0
 Fax +49 (7821) 9 94 69 – 100



Internet: <http://www.jms.aero/>
 eMail: <mailto:sales@jms.aero>

HRB 705130 Amtsgericht Freiburg i.Br.
 VAT Reg No/USSt.-IdNr.: DE270217003

Doc. No. TDS J-TOWhead-BD16_R00.docx

Datasheet:

p/n: J-TOWhead-BD16

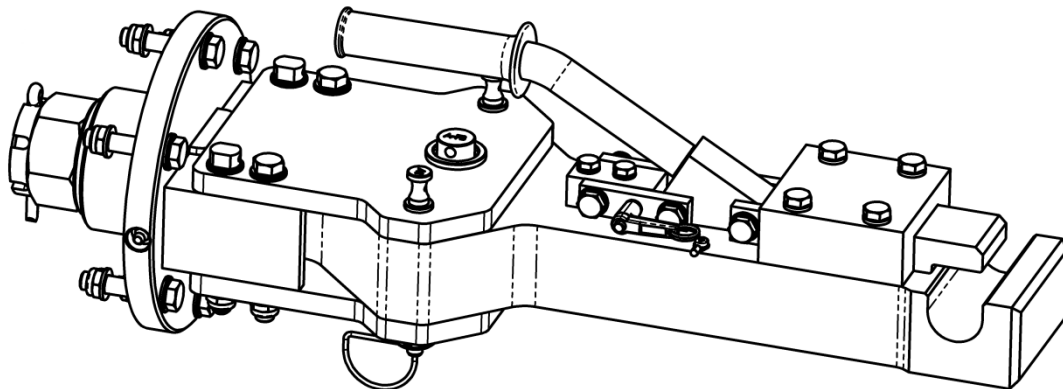

Standard features:

- Push/Pull and torque shear pin
- 4 spare shear pins included
- Retaining pin
- Revolving tow head $\pm 10^\circ$
 (requirement as per Airbus MFP
 for A318/A319/A320/A321 a/c)
- All steel parts corrosion-resistant
- Incl. label aircraft-type

Options (at extra charges):

-

Aircraft application:

- A318/A319/A320/A321

Documentation:

- Technical manual incl. illustrated spare parts list
- COC Certificate of Conformity
- CE Declaration of Conformity (if applicable)

Net weight:

- 48 kg / 106 lbs

Shear pins:

- 20-00730-0020-022 "A1" Push/Pull and Torque
- 00.38910.0007 "A-FB" Retaining pin

Shipping information incl. packing:

Approx. Weight	Approx. shipping Dims l x w x h	Approx. Volume
[kg] 73	[mm] 600 x 250 x 360	[m ³] 0,05
[lbs] 161	[inch] 23.6 x 10 x 14	[ft ³] 1,7

We reserve the right to update this datasheet at any time w/o prior notice!