

**JMS AG**  
 Jet Maintenance & Service  
 Rainer-Haungs-Strasse 42  
 77933 Lahr/Germany  
 Phone +49 (7821) 9 94 69 – 0  
 Fax +49 (7821) 9 94 69 – 100



Internet: <http://www.jms.aero/>  
 eMail: <mailto:sales@jms.aero>

HRB 705130 Amtsgericht Freiburg i.Br.  
 VAT Reg No/UST.-IdNr.: DE270217003

Doc. No. TDS J-TOWhead-D46\_R01.doc

**Datasheet:**

**p/n: J-TOWhead-D46**

Towhead for Challenger 300 / Saab 340 / 2000

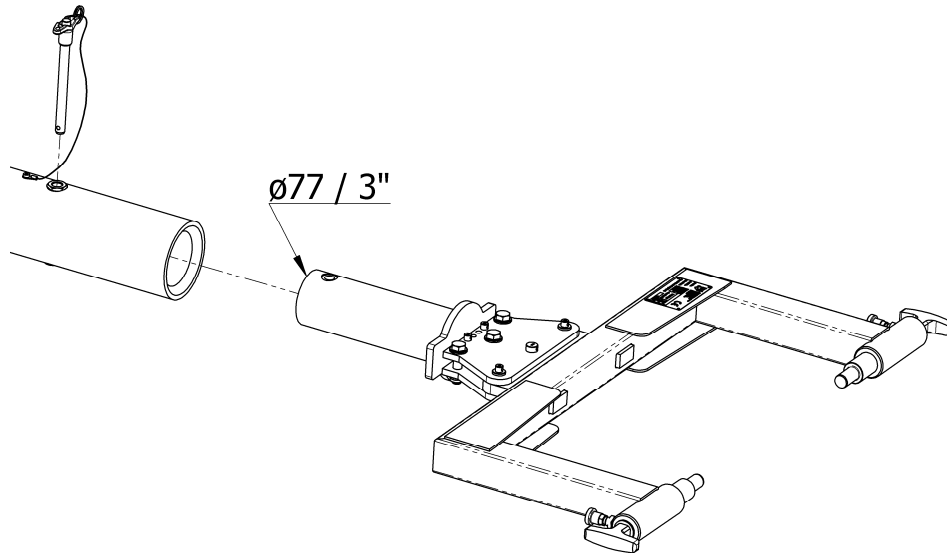

**Features:**

- Towhead for **J-TOWbiz1** – Towbar. Also compatible to other universal towbars (e.g. TronAir) with  $\varnothing 77\text{mm}$  /  $\varnothing 3\text{''}$  adapter system.
- Also compatible to J-TOWbiz2 and J-TOWbiz3 – Towbar and to other universal tow bars with  $\varnothing 83\text{ mm}$  /  $\varnothing 3\frac{1}{4}\text{''}$  adapter system (additional adapter necessary)
- Quick release pin system for easy towhead replacement
- Push/Pull and torque shear pin
- 2 spare shear pins included
- Retaining pin
- All steel parts corrosion-resistant

**Documentation:**

- Technical manual incl. illustrated spare parts list
- COC Certificate of Conformity
- CE Declaration of Conformity (if applicable)

**Aircraft application:**

- Challenger 300
- Saab 340 / Saab 2000

**Net weight:**

- 18 kg / 39 lbs

**Shear pins:**

- 20-00070-0020-022 “AG” Push/Pull and Torque
- 20-00070-0020-021 “AG-FB” Retaining pin

**Shipping information incl. packing:**

Approx. Weight	Approx. shipping Dims l x w x h	Approx. Volume
[kg] <b>42</b>	[mm] <b>1200 x 800 x 250</b>	[m <sup>3</sup> ] <b>0,24</b>
[lbs] <b>92</b>	[inch] <b>47.2 x 31.5 x 9.8</b>	[ft <sup>3</sup> ] <b>8.48</b>

We reserve the right to update this datasheet at any time w/o prior notice!