

JMS AG
 Jet Maintenance & Service
 Rainer-Haungs-Strasse 42
 77933 Lahr/Germany
 Phone +49 (7821) 9 94 69 – 0
 Fax +49 (7821) 9 94 69 – 100



Internet: <http://www.jms.aero/>
 eMail: <mailto:sales@jms.aero>

HRB 705130 Amtsgericht Freiburg i.Br.
 VAT Reg No/USt.-IdNr.: DE270217003

Doc. No. TDS_J-TOWversa4_R02.docx

Datasheet:

p/n: J-TOWversa4

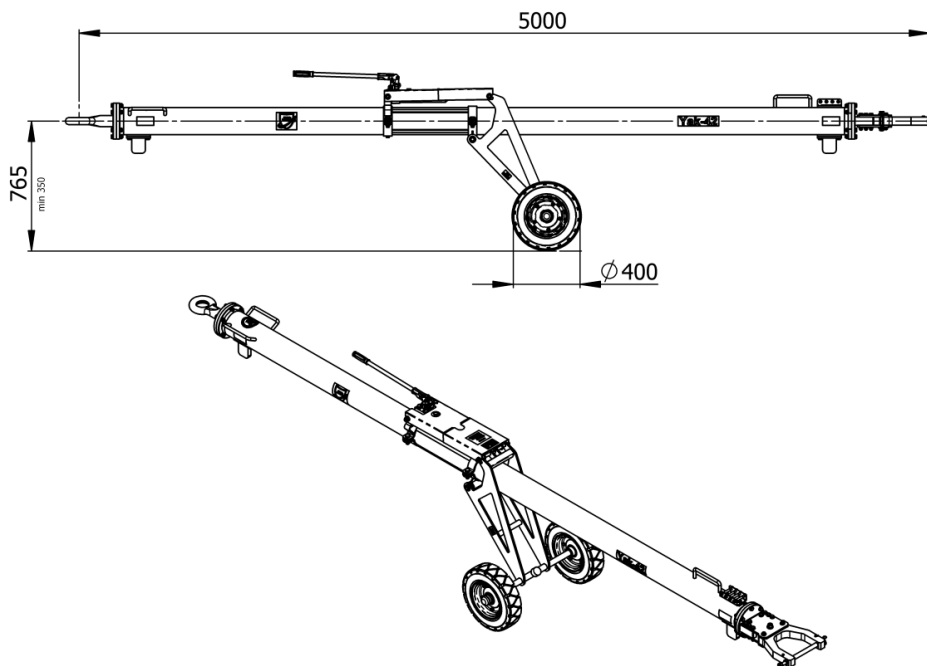

Standard features:

- 2xShearpins for Push/Pull / torque mounted (add. as spare parts incl.: 4xShearpins)
- 1xRetaining pin
- Air-inflated tires
- Hydraulically height adjustable undercarriage
- Steel tube
- Skydrol resistant paint
- Standard colors:
 yellow RAL 1007 (tube),
 black RAL 9004 (undercarriage)

Aircraft application:

- Yak-42
- TU-154
- Mi-26

Net weight:

- 220 kg / 485 lbs

Shipping information incl. packing:

Approx. Weight	Approx. shipping Dims l x w x h	Approx. Volume
[kg] 285	[mm] 5200 x 1000 x 830	[m ³] 4,3
[lbs] 628	[inch] 205 x 39 x 33	[ft ³] 151.8

Options (at extra charges):

- Puncture-proof (full rubber) tires
 → Option R4
- Revolving tow eye
 → Option BP
- Revolving tow eye with shock absorber
 → Option BA
- Customized color for towbar tube i.a.w. RAL coding scheme
 → Option B-RAL

Documentation:

- Technical manual incl. illustrated spare parts list
- COC Certificate of Conformity
- CE Declaration of Conformity (if applicable)

Shear pins:

- 00.37200.0012 “H” Push/Pull and Torque
- 00.37720.0018 “U-FB” Retaining pin